

## *Research Article*

# **Particle Swarm Optimization with Various Inertia Weight Variants for Optimal Power Flow Solution**

**Prabha Umapathy,<sup>1</sup> C. Venkateshaiah,<sup>1</sup>  
and M. Senthil Arumugam<sup>2</sup>**

<sup>1</sup> Faculty of Engineering and Technology, Multimedia University, Jalan Ayer Keroh Lama, Melaka 75450, Malaysia

<sup>2</sup> Teaching Fellow, School of Engineering and Physical Sciences, Heriot-Watt University, Dubai, United Arab Emirates

Correspondence should be addressed to Prabha Umapathy, prabha.umapathy@mmu.edu.my

Received 26 April 2010; Accepted 30 June 2010

Academic Editor: B. Sagar

Copyright © 2010 Prabha Umapathy et al. This is an open access article distributed under the Creative Commons Attribution License, which permits unrestricted use, distribution, and reproduction in any medium, provided the original work is properly cited.

This paper proposes an efficient method to solve the optimal power flow problem in power systems using Particle Swarm Optimization (PSO). The objective of the proposed method is to find the steady-state operating point which minimizes the fuel cost, while maintaining an acceptable system performance in terms of limits on generator power, line flow, and voltage. Three different inertia weights, a constant inertia weight (CIW), a time-varying inertia weight (TVIW), and global-local best inertia weight (GLbestIW), are considered with the particle swarm optimization algorithm to analyze the impact of inertia weight on the performance of PSO algorithm. The PSO algorithm is simulated for each of the method individually. It is observed that the PSO algorithm with the proposed inertia weight yields better results, both in terms of optimal solution and faster convergence. The proposed method has been tested on the standard IEEE 30 bus test system to prove its efficacy. The algorithm is computationally faster, in terms of the number of load flows executed, and provides better results than other heuristic techniques.

## **1. Introduction**

In the past two decades, the problem of optimal power flow (OPF) has received much attention. The OPF problem solution aims to optimize a selected objective function such as fuel cost via optimal adjustment of the power system control variables, while at the same time satisfying various equality and inequality constraints. The equality constraints are the power flow equations, and the inequality constraints are the limits on the control variables and the operating limits of power system dependent variables. Generally, the OPF problem is a large-scale highly constrained nonlinear nonconvex optimization problem. This is widely used in power system operation and planning. Many techniques such as nonlinear

programming [1–3], linear programming [4–6], quadratic programming [7], Newton-based techniques [8, 9], and interior point methods [10, 11] have been applied to the solution of OPF problem.

Nonlinear programming has many drawbacks such as algorithmic complexity. Linear programming methods are fast and reliable but require linearization of objective function as well as constraints with nonnegative variables. Quadratic programming is a special form of nonlinear programming which has some disadvantages associated with piecewise quadratic cost approximation. Newton-based method has a drawback of the convergence characteristics that are sensitive to initial conditions. The interior point method is computationally efficient but suffers from bad initial termination and optimality criteria. The problem of the OPF is highly nonlinear, where more than one local optimum exists. Hence the above-mentioned local optimization techniques are not suitable for such a problem. Therefore the conventional optimization methods are not able to identify the global optimum. Hence it becomes essential to develop optimization techniques that are efficient to overcome these drawbacks and handle such complexity.

Heuristic algorithms such as Genetic Algorithm (GA) [12] and evolutionary programming [13] have been recently proposed for solving OPF problem. But the recent research has identified some deficiencies in the performance of GA [14] in terms of premature convergence. Recently, a new evolutionary computation technique called particle swarm optimization (PSO) has been proposed [15–17]. PSO is a flexible, robust, population-based stochastic search for optimization problem. In the recent years, this method has gained popularity over other methods and is increasingly gaining acceptance for solving optimal power flow problems and also a variety of power system problems [18–22]. Due to its simplicity, superior convergence characteristics and high accuracy, the PSO technique is also applied to more complex power system problems [23–25]. More discussions are presented as a comprehensive survey in [26]. This paper deals with an efficient PSO algorithm for OPF problem, and the impacts of inertia weight variants are analyzed. The proposed method provides the results with better accuracy and less convergence time.

A brief introduction has been provided in this section for the existing optimization techniques that have been applied to power system problems. The rest of the paper is arranged as follows. In Section 2, the optimal power flow problem is formulated and discussed. In Section 3, the basic concepts of PSO are explained. The selection of PSO parameters is highlighted in Section 4. Section 5 presents the algorithm used in the present work. Section 6 provides the details of the test system on which the proposed algorithm is tested and the results are presented. Finally concluding remarks appear in Section 7.

## 2. Problem Formulation for OPF Solution

The optimal power flow problem is a nonlinear optimization problem with nonlinear objective function and nonlinear constraints. The OPF problem considered in this paper is to optimize the steady-state performance of a power system in terms of the total fuel cost while satisfying several equality and inequality constraints.

Mathematically, the OPF problem can be formulated as follows.

$$\text{Minimize } F(x, u) \quad (2.1)$$

$$\begin{aligned} \text{subject to } g(x, u) &= 0, \\ h(x, u) &\leq 0, \end{aligned} \quad (2.2)$$

where  $x$  is the vector of dependent variables and  $u$  is the vector of independent variables

$$\begin{aligned} x^T &= [P_{G1} \ V_L^T \ Q_G^T \ S_l^T], \\ u^T &= [P_G^T \ V_G^T \ t^T \ Q_{SH}^T]. \end{aligned} \quad (2.3)$$

The load flow equations are

$$P_{Gi} - P_{Di} - V_i \sum_{j \neq i} V_j (G_{ij} \sin \theta_{ij} + B_{ij} \cos \theta_{ij}) = 0, \quad (2.4)$$

$i \in n$ , where set of numbers of buses except the swing bus

$$Q_{Gi} - Q_{Di} - V_i \sum_{j \neq i} V_j (G_{ij} \cos \theta_{ij} - B_{ij} \sin \theta_{ij}) = 0, \quad (2.5)$$

$i \in n$ , where set of numbers of buses except the swing bus.

The fuel cost function is given as

$$F = \sum_{i=1}^{N_G} f_i \left( \frac{\$}{h} \right). \quad (2.6)$$

The generator cost curves are represented by quadratic function as

$$f_i = \left( a_i + b_i P_{Gi} + c_i P_{Gi}^2 \right) \left( \frac{\$}{h} \right). \quad (2.7)$$

Vector  $x$  consists of dependent variables, and vector  $u$  consists of control variables. The variables  $h(x, u)$  comprise a set of system operating constraints that includes the following.

#### (a) Generation Constraints

Generator voltages, real power outputs, and reactive power outputs are restricted by their lower and upper limits as follows:

$$\begin{aligned} V_{Gi}^{\min} &\leq V_{Gi} \leq V_{Gi}^{\max}, \quad i = 1, \dots, N_G, \\ P_{Gi}^{\min} &\leq P_{Gi} \leq P_{Gi}^{\max}, \quad i = 1, \dots, N_G, \\ Q_{Gi}^{\min} &\leq Q_{Gi} \leq Q_{Gi}^{\max}, \quad i = 1, \dots, N_G. \end{aligned} \quad (2.8)$$

#### (b) Transformer Constraints

Transformer tap settings are bounded as follows:

$$T_i^{\min} \leq T_i \leq T_i^{\max}, \quad i = 1, \dots, N_T. \quad (2.9)$$

*(c) Shunt VAR Constraints*

Shunt VAR compensations are restricted by their limits as follows:

$$Q_{ci}^{\min} \leq Q_{ci} \leq Q_{ci}^{\max}, \quad i = 1, \dots, N_c. \quad (2.10)$$

*(d) Security Constraints*

The constraints of the voltages at load buses and transmission line loadings are considered as follows:

$$\begin{aligned} V_{Li}^{\min} \leq V_{Li} \leq V_{Li}^{\max}, \quad i = 1, \dots, N_L, \\ S_{li} \leq S_{li}^{\max}, \quad i = 1, \dots, n_l, \end{aligned} \quad (2.11)$$

where  $F$  is objective function,  $g$  equality constraints,  $h$  operating constraints,  $P_{G1}$  slack bus power,  $P_{Gi}$  real power output of generator  $i$ ,  $P_{Di}$  real power load of bus  $i$ ,  $Q_{Gi}$  reactive power output of generator  $i$ ,  $Q_{Di}$  reactive power load of bus  $i$ ,  $V_L$  load bus voltages,  $V_i$  voltage magnitude of bus  $i$ ,  $\theta_i$  voltage phase angle of bus  $i$ ,  $\theta_{ij}$  phase angle difference between buses  $i$  and  $j$ ,  $G_{ij}$  mutual conductance between buses  $i$  and  $j$ ,  $B_{ij}$  mutual susceptance between buses  $i$  and  $j$ ,  $N_G$  number of generator buses,  $N_L$  number of load buses,  $N_T$  number of transformers,  $N_c$  number of shunt VAR compensators,  $n_l$  number of lines,  $S_l$  transmission line loadings,  $V_{Gi}^{\min}$ ,  $V_{Gi}^{\max}$  bus voltage limit,  $P_{Gi}^{\min}$ ,  $P_{Gi}^{\max}$  generator real power limit,  $Q_{Gi}^{\min}$ ,  $Q_{Gi}^{\max}$  generator reactive power limit,  $T_i^{\min}$ ,  $T_i^{\max}$  transformer tap position limit,  $Q_{ci}^{\min}$ ,  $Q_{ci}^{\max}$  reactive power source installation capacity limit.

### 3. Particle Swarm Optimization

#### 3.1. Overview of PSO

PSO has been developed through simulation of simplified social models. The features of the method are as follows.

- (a) The method is based on researches about swarms such as fish schooling and a flock of birds.
- (b) It is based on a simple concept. Therefore, the computation time is short and it requires less memory.
- (c) It was originally developed for nonlinear optimization problems with continuous variables. However, it is easily expanded to treat problems with discrete variables. Therefore, it is applicable for the OPF problem which is having both continuous and discrete variables.

The previous feature (c) is suitable for the OPF problem because it is practically efficient method which can handle both continuous and discrete variables. The previous features allow PSO to effectively handle the problem and it requires only short computation time.

According to the research results for a flock of birds, birds find food by flocking (not by each individual). The observation leads the assumption that all information is

shared inside flocking. Moreover, according to observation of behavior of human groups, behavior of each individual (agent) is also based on behavior patterns authorized by the groups such as customs and other behavior patterns according to the experiences by each individual. PSO was developed through simulation of a simplified social system, and has been found to be robust in solving continuous nonlinear optimization problems. The PSO technique can generate a high-quality solution within shorter calculation time and stable convergence characteristic than other stochastic methods. Researchers have presented PSO solving techniques applied to OPF, economic dispatch problem, available transfer capability problem, reactive power optimization problem in the recent past. Many researches are still in progress for proving the potential of the PSO in solving complex power system operation problems.

### 3.2. Implementation of PSO for Optimal Power Flow Problems

A swarm consists of a set of particles moving within the search space, each representing a potential solution (fitness). In a physical  $n$ -dimensional search space, the position and velocity of each particle  $i$  are represented as the vectors  $X_i = (x_{i1}, \dots, x_{in})$  and  $V_i = (v_{i1}, \dots, v_{in})$ , respectively. Searching procedures by PSO based on the above concept can be described as follows. A flock of agents optimizes a certain objective function. Each individual knows its best value  $Pbest$  so far and its position. Moreover, each individual knows the best value in the group  $Gbest$  among  $pbest$ . Let  $Pbest_i = (x_{i1}^{pbest}, \dots, x_{in}^{pbest})$  and  $Gbest_i = (x_{i1}^{gbest}, \dots, x_{in}^{gbest})$  be the position of the individual  $i$  and its neighbor's best position so far. Using this information, the modified velocity of each individual can be calculated using the current velocity and the distance from  $Pbest$  and  $Gbest$  as shown in

$$V_i^{k+1} = \omega V_i^k + c_1 \text{rand}_1 \times (Pbest_i^k - X_i^k) + c_2 \text{rand}_2 \times (Gbest_i^k - X_i^k), \quad (3.1)$$

where  $V_i^k$  is current velocity of individual  $i$  at iteration  $k$ ,  $V_i^{k+1}$  modified velocity of individual  $i$  at iteration  $k + 1$ ,  $X_i^k$  current position of individual  $i$  at iteration  $k$ ,  $\omega$  inertia weight parameter,  $c_1$ ,  $c_2$  acceleration factors,  $\text{rand}_1$ ,  $\text{rand}_2$ : random numbers between 0 and 1,  $Pbest_i^k$ : best position of individual  $i$  until iteration  $k$ ,  $Gbest_i^k$ : best position of the group until iteration  $k$ .

Each individual moves from the current position to the next one by the modified velocity in (3.1) using the following equation:

$$X_i^{k+1} = X_i^k + V_i^{k+1}. \quad (3.2)$$

The parameters  $c_1$  and  $c_2$  are set to constant values. Low values allow individual to roam far from the target regions before being tugged back. On the other hand, high values result in abrupt movement towards target regions. Hence the acceleration constants  $c_1$  and  $c_2$  are normally set as 2.0 whereas  $\text{rand}_1$  and  $\text{rand}_2$  are random values, and they are uniformly distributed between zero and one. These values are not the same for each iteration because they are generated randomly every time.

The search mechanism of the PSO using the modified velocity and position of the individual  $i$  based on (3.1) and (3.2) is illustrated in Figure 1.

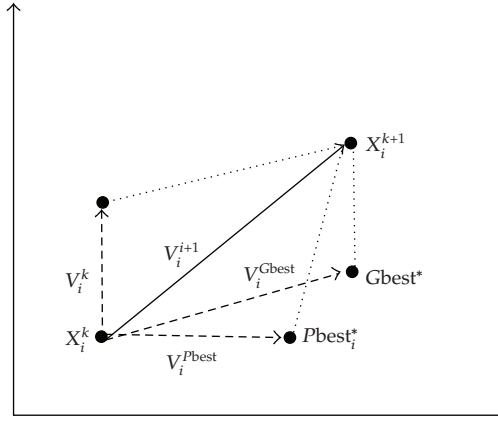

Figure 1: Search mechanism of PSO.

### 3.3. PSO Algorithm

The general PSO algorithm is presented below.

- (1) The technique is initialized with a population of random solutions or particles and then searches the optima by updating generations. Each individual particle  $I$  has the three following properties: a current position in search space  $x_i$ , a current velocity  $v_i$ , and a personal best position in search space  $y_i$ .
- (2) In every iteration, each particle is updated by the following two best values. The first one is the personal best position  $y_i$  which is the position of the particle  $i$  in the search space, where it has reached the best solution so far. The second one is the global best solution  $y^*$  which is the position yielding the best solution among all the  $y_i$ 's. The  $pbest$  and  $gbest$  values are updated at time  $t$  using the following (3.3) and (3.4), respectively. Here it is assumed that the swarm has  $s$  particles. Therefore,  $i \in 1, \dots, s$  and assuming the minimization of the objective function  $F$ ,

$$y_i(t+1) = \begin{cases} y_i(t), & \text{if } f(y_i(t)) \leq f(x_i(t+1)), \\ x_i(t+1), & \text{if } f(y_i(t)) > f(x_i(t+1)), \end{cases} \quad (3.3)$$

$$y^*(t) \in \{y_1(t), \dots, y_s(t)\}, \quad (3.4)$$

$$f(y^*(t)) = \min\{f(y_1(t)), \dots, f(y_s(t))\}.$$

- (3) After finding the two best values, each particle updates its velocity and current position. The velocity of the particle is updated according to its own previous best position and the previous best position of its companions which is given in (3.1).

This new velocity is added to the current position of the particle to obtain its next position by using (3.2).

- (4) The acceleration coefficients control the distance moved by a particle in the iteration. The inertia weight controls the convergence behavior of PSO. Initially the inertia weight was considered as a constant value. However, experimental results indicated that it is better to initially set the inertia weight to larger value and gradually reduce it to get refined solutions. A new inertia weight which is neither set to a constant value nor set as a linearly decreasing time-varying function is used in this paper and appears in (4.2).

## **4. Experimental Parameter Settings**

### **4.1. Initial Population**

The initial populations are generated randomly, and it is a set of  $n$  particles at time  $t$ .

### **4.2. Swarm**

It is an apparently disorganized population of moving particles that tend to cluster together while each particle seems to be moving in a random direction.

### **4.3. Population Size**

From the earlier research performed by Eberhart and Shi [27], it is proved that the performance of the standard algorithm is not sensitive to the population size but to the convergence rate. Based on these results, the population size in the present work is fixed at 20 particles in order to keep the computational requirements low.

### **4.4. Search Space**

The range in which the algorithm computes the optimal control variables is called search space. The algorithm will search for the optimal solution in the search space between 0 and 1. When any of the optimal control values of any particle exceed the searching space, the value will be reinitialized. In this paper, the lower and upper boundaries are set to 0 and 1.

### **4.5. Maximum Generations**

This refers to the maximum number of generations allowed for the fitness value to converge with the optimal solution. In this paper, the maximum generation is set as 200.

### **4.6. Inertia Weight Considerations**

#### **4.6.1. Constant Inertia Weight (CIW)**

The conventional PSO algorithm initially used a constant value for the inertia weight.

#### 4.6.2. Time-Varying Inertia Weight (TVIW)

In order to improve the performance of the PSO, the time-varying inertia weight was proposed in [24]. This inertia weight linearly decreases with respect to time. Generally for initial stages of the search process, large inertia weight to enhance the global exploration (searching new area) is recommended while, for last stages, the inertia weight is reduced for local exploration (fine tuning the current search area). The mathematical expression for the same is given as follows:

$$\text{Inertia weight } \omega = (\omega_1 - \omega_2) \left( \frac{\text{maxiter} - \text{iter}}{\text{iter}} \right) + \omega_2, \quad (4.1)$$

where  $\omega_1$  is initial value of the inertia weight,  $\omega_2$  final values of the inertia weight, iter current iteration, the max iter the maximum number of allowable iterations.

#### 4.6.3. Inertia Weight Used in the Present Work (GLbestIW)

The GLbestIW method is proposed in [28] in which, the inertia weight is neither set to a constant value nor set as linearly decreasing time-varying function. The inertia weight is defined as a function of local best ( $pbest$ ) and global best ( $gbest$ ) values of the particles in each generation. The GLbest inertia weight is given by the following equation

$$\text{Inertia weight } \omega_i = \left( 1.1 - \frac{gbest_i}{(pbest_i)} \right). \quad (4.2)$$

## 5. Flow Chart and Implementation of the Proposed PSO Technique

### 5.1. Flowchart

Figure 2 shows the flowchart for the PSO based on the Global-Local best inertia weight technique used in this paper.

### 5.2. Implementation

The proposed PSO algorithm was implemented using MATLAB 7.0 software. PSO parameters are selected as shown in Table 1.

## 6. Simulation and Results

### 6.1. IEEE 30 Bus Test System

The proposed algorithm is implemented and tested on a standard IEEE 30 bus test system as shown in Figure 3. The brief description of the test bus system is given in Table 2, and the single line diagram of the network is shown in Figure 3. The system has 6 generators at buses 1, 2, 5, 8, 11, and 13 and four transformers with off-nominal tap ratio in lines 6–9, 6–10, 4–12 and 28–27. Detailed analyses of the results are presented and discussed in this section.



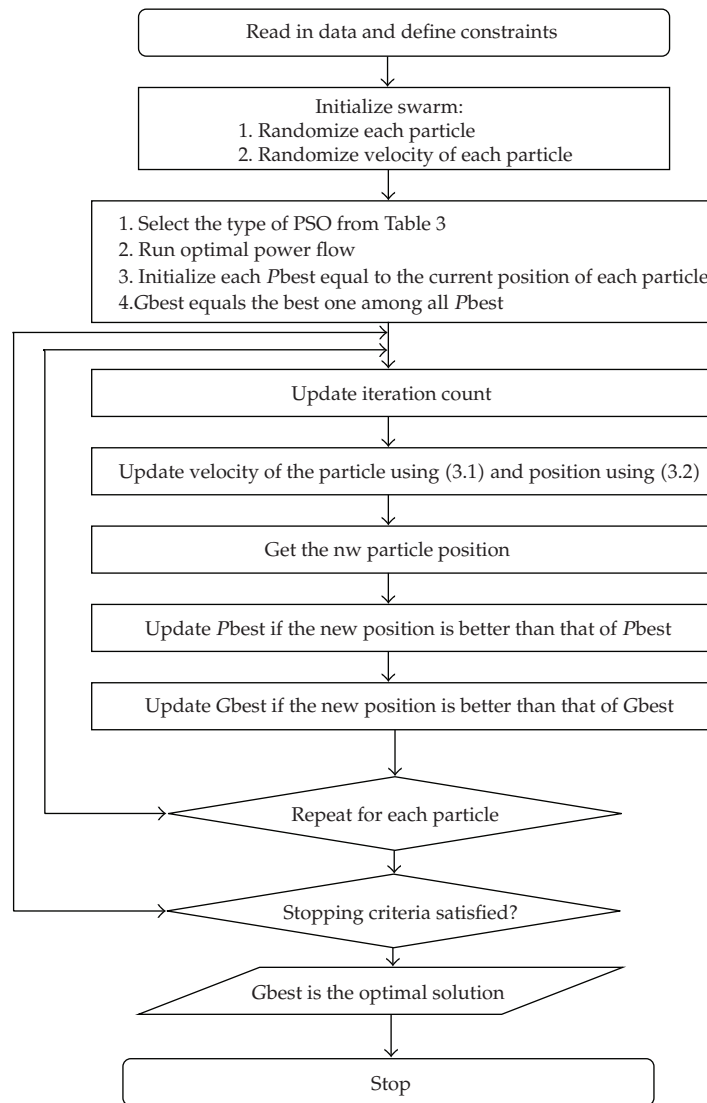

Figure 2: Flow chart for the proposed technique.

The limits for different variables are given in Table 3. The cost coefficients for the system under consideration are given in Table 4. The state variable constraints of IEEE 30 bus test system are given in Table 5.

## 6.2. Various Optimization Methods

The three methods listed in Table 6 are simulated 200 times at different periods of time, and their statistical analyses are recorded. The *mean* or *average standard deviations (SDs)* are the basic statistical tests. These statistical analyses are presented in this section.

**Table 1:** PSO parameters.

Population size	20
Generations	200
Acceleration coefficients	2
Inertia weight	As proposed in (4.2)
Number of load flows (Population $\times$ Generations)	4000
Stopping criteria	(i) When the difference between the results of the two consecutive iterations is $\leq 0.000001$ (ii) The number of iterations reaches 200

**Table 2:** System description.

S.no.	Variables	IEEE 30 bus test system
(1)	Number of buses	30
(2)	Number of branches	41
(3)	Number of generators	6
(4)	Number of generator buses	6
(5)	Number of shunts	9
(6)	Number of tap-changing transformers	4

**Table 3:** Limits for the different variables for IEEE 30 bus test system.

S.no.	Description	Units	Variable type	Lower limit	Upper limit
(1)	Generator bus voltage	p.u	Continuous	0.95	1.05
(2)	Load bus voltage	p.u	Continuous	0.95	1.10
(3)	Transformer taps	p.u	Discrete	0.90	1.10
(4)	Shunt capacitor	p.u	Discrete	0.0	0.05

**Table 4:** Generator cost coefficients for IEEE 30 bus test system.

	$G_1$	$G_2$	$G_5$	$G_8$	$G_{11}$	$G_{13}$
$a_i$	0.00375	0.0175	0.0625	0.0083	0.025	0.025
$b_i$	2.0	1.75	1.0	3.25	3.0	3.0
$c_i$	0.0	0.0	0.0	0.0	0.0	0.0

The average deviation which gives the average of the absolute deviation of the fitness value from their mean is also tabulated. Added to these analyses, *hypothesis t test* and *analysis of variance* (ANOVA) test were also conducted to validate the efficiency of the three different methods. These statistical analyses are presented in Tables 7 and 8. The graphical analysis of the ANOVA test is shown in Figure 4.

Table 9 gives the minimum, maximum, and average costs for 1st trial, 100 trials and 200 trials for all the three PSO methods under consideration. It can be seen that the minimum cost as well as the average cost produced by GLBestIW PSO is the least as compared to other methods. This emphasizes the better quality solution of the proposed method. Table 10 presents the generator outputs and the best cost achieved by the different PSO algorithms for the 30-bus test system while satisfying the constraints. All the methods achieve the global

**Table 5:** State Variable Constraints for IEEE 30 bus test system.

Bus	$P_{\min}$	$P_{\max}$	$Q_{\min}$	$Q_{\max}$	$V_{\min}$	$V_{\max}$
1	50	200	-20	200	0.95	1.10
2	20	80	-20	100	0.95	1.10
5	15	50	-15	80	0.95	1.10
8	10	35	-15	60	0.95	1.10
11	10	30	-10	50	0.95	1.10
13	12	40	-15	60	0.95	1.10

**Table 6:** Various Methods.

Method name	Description
PSO-1	PSO with constant inertia weight (CIW)
PSO-2	PSO with time-varying inertia weight (TVIW)
PSO-3	PSO with proposed global-local best inertia weight (GLbestIW)

**Table 7:** Statistical Analyses of fitness value in 100th iteration.

Stat.test	Average	SD	AVEDEV	$t$ test for 100th iteration		
				Method no.	$P$ value	Best method
PSO-1	803.8812	0.2562	0.0757	1 and 2	.97192	2
PSO-2	802.4946	0.1188	0.0716	2 and 3	.00000	3
PSO-3	801.8441	0.0002	0.0002			

**Table 8:** Statistical Analyses of fitness value in 200th iteration.

Stat.test	Average	SD	AVEDEV	$t$ test for 100th iteration		
				Method no.	$P$ value	Best method
PSO-1	803.8449	0.00794	0.00248	1 and 2	.98799	2
PSO-2	802.8438	0.0008	0.0003	2 and 3	1.00000	3
PSO-3	801.8438	0.0001	0.0001			

**Table 9:** Comparison of different PSO methods.

S. no.	Number of trails	Method	Min. cost	Max. cost	Average
(1)	1	CIW	802.959	822.351	809.587
		TVIW	802.741	824.391	809.741
		GLBestIW	801.113	816.277	807.828
(2)	100	CIW	802.843	804.921	803.881
		TVIW	802.543	802.551	802.494
		GLBestIW	801.843	801.845	801.844
(3)	200	CIW	802.843	804.913	803.844
		TVIW	802.543	802.852	802.843
		GLBestIW	801.843	801.845	801.843

minimum solution, but comparatively, the GLBestIW PSO has better consistency and also achieved global minimum.

Table 11 shows the comparison between the existing methods and the proposed GLBestIW method. The comparison has been made for the results obtained from Matpower (Matpower is a powerful tool created by Professor Ray Zimmerman and Professor Deqiang

**Table 10:** Generator output.

Unit power output	CIW	TVIW	GLBestIW
$P_1$ (MW)	175.73	176.23	176.72
$P_2$ (MW)	48.83	48.94	48.96
$P_5$ (MW)	21.47	21.42	21.52
$P_8$ (MW)	21.65	21.34	21.57
$P_{11}$ (MW)	12.09	12.23	12.37
$P_{13}$ (MW)	12	12	12.02
Total power Output (MW)	291.771	292.16	293.16
Cost (\$/h)	802.843	802.543	801.843

**Table 11:** Performance comparison.

Parameter	Matpower	CPSO	GLBestIW PSO
$P_1$ (MW)	176.2	179.2	176.74
$P_2$ (MW)	48.79	48.3	48.8
$P_5$ (MW)	21.48	20.92	21.47
$P_8$ (MW)	22.07	20.56	21.64
$P_{11}$ (MW)	12.19	11.57	12.14
$P_{13}$ (MW)	12.00	12.48	12.00
Cost (\$/hr)	802.1	802.0	801.84

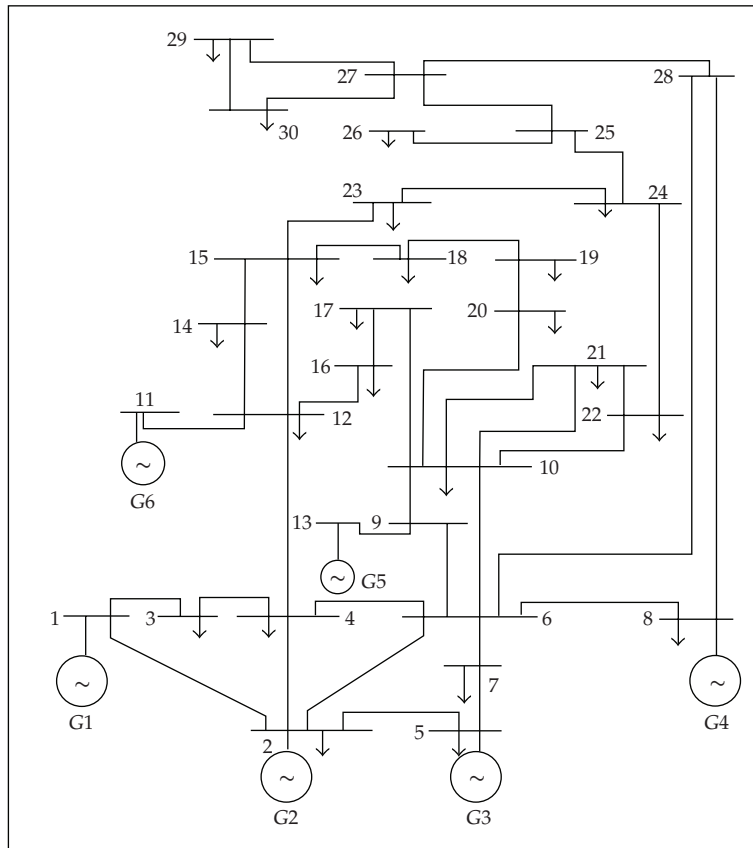

**Figure 3:** IEEE 30 bus test system.

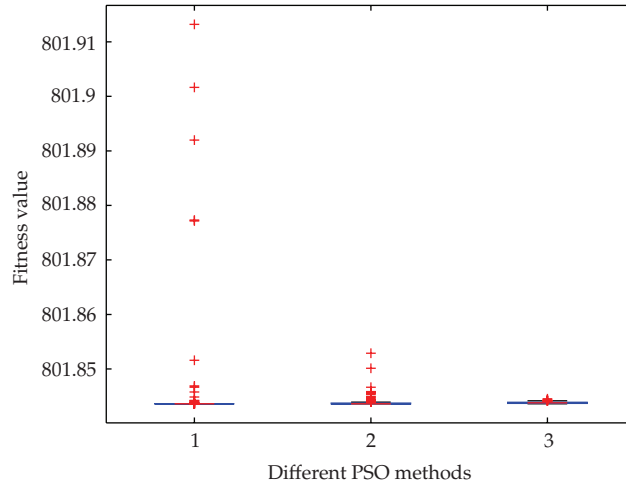

Figure 4: ANOVA test for the different PSO methods.

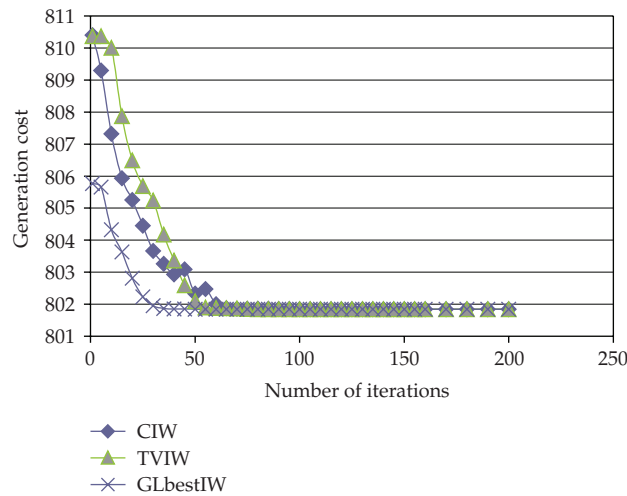

Figure 5: Comparison graph for the different PSO methods.

Gan of PSERC at Cornell University under the direction of Professor Robert Thomas), conventional particle swarm optimization technique (cPSO) and the GLBestIW technique.

Figure 5 shows the convergence plot. From the plot, it is clearly identified that the proposed method converges faster than that of the other methods. It could be observed that the constant IW (CIW) method takes 60 iterations and the Time-Varying IW (TVIW) method takes 50 iterations, while the proposed method converges in 20 iterations. This shows the computational efficiency of the proposed method.

### 7. Conclusion

This paper presents a GLbestIW-based PSO technique for the solution of optimal power flow problem in a power system. The results of study on the impact of inertia weight for improving the performance of the PSO to obtain the optimal power flow solution are

presented and discussed. The OPF problem considered in this paper is to minimize the fuel cost and determine the control strategy with continuous and discrete control variables, such as generator bus voltages, transformer tap positions, and reactive power installations. The performance of the proposed GLbestIW-based PSO has been validated on the standard IEEE 30 bus test system. It is shown through different trials that the GLbestIW PSO outperforms other methods in terms of high quality solution, consistency, faster convergence, and accuracy.

## References

- [1] J. Nocedal and S. J. Wright, *Numerical Optimization*, Springer Series in Operations Research, Springer, New York, NY, USA, 1999.
- [2] W. Hua, H. Sasaki, J. Kubokawa, and R. Yokoyama, "An interior point non linear programming for optimal power flow problem with a novel data structure," *IEEE Transactions on Power Systems*, vol. 13, no. 3, pp. 870–877, 1998.
- [3] G. Torres and V. Quintana, "On a non linear multiple-centrality corrections interior-point method for optimal power flow," *IEEE Transactions on Power Systems*, vol. 16, no. 2, pp. 222–228, 2001.
- [4] K. Ng and G. Shelbe, "Direct load control—a profit-based load management using linear programming," *IEEE Transactions on Power Systems*, vol. 13, no. 2, pp. 688–694, 1998.
- [5] R. Jabr, A. H. Coonick, and B. Cory, "A homogeneous linear programming algorithm for the security constrained economic dispatch problem," *IEEE Transactions on Power Systems*, vol. 15, no. 3, pp. 930–936, 2000.
- [6] D. Kirschen and H. Van Meeteren, "MW/voltage control in a linear programming based optimal power flow," *IEEE Transactions on Power Systems*, vol. 3, no. 2, pp. 481–489, 1988.
- [7] R. C. Burchett, H. H. Happ, and K. A. Wirgau, "Large scale optimal power flow," *IEEE Transactions on Power Systems*, vol. 101, pp. 3722–3732, 1982.
- [8] D. I. Sun, B. Ashley, B. Brewer, A. Hughes, and W. F. Tinney, "Optimal power flow by Newton approach," *IEEE Transactions on Power Systems*, vol. 103, pp. 2864–2880, 1984.
- [9] A. Santos and G. R. da Costa, "Optimal power flow by Newton's method applied to an augmented lagrangian function," *IEE Proceedings Generation, Transmission & Distribution*, vol. 142, no. 1, pp. 33–36, 1998.
- [10] X. Yan and V. H. Quintana, "Improving an interior point based OPF by dynamic adjustments of step sizes and tolerances," *IEEE Transactions on Power Systems*, vol. 14, no. 2, pp. 709–717, 1999.
- [11] J. A. Momoh and J. Z. Zhu, "Improved interior point method for OPF problems," *IEEE Transactions on Power Systems*, vol. 14, no. 3, pp. 1114–1120, 1999.
- [12] L. L. Lai and J. T. Ma, "Improved Genetic algorithms for optimal powerflow under both normal and contingent operation states," *International Journal of Electrical Power Energy Systems*, vol. 19, no. 5, pp. 287–292, 1997.
- [13] J. Yuryevich and K. P. Wong, "Evolutionary programming based optimal power flow algorithm," *IEEE Transactions on Power Systems*, vol. 14, no. 4, pp. 1245–1250, 1999.
- [14] D. B. Fogel, *Evolutionary Computation towards a New Philosophy of Machine Intelligence*, IEEE Press, New York, NY, USA, 1995.
- [15] J. Kennedy, "Particle swarm: social adaptation of knowledge," in *Proceedings of the IEEE Conference on Evolutionary Computation (ICEC '97)*, pp. 303–308, Indianapolis, Ind, USA, 1997.
- [16] P. Angeline, "Evolutionary optimization versus particle swarm optimization: philosophy and performance differences," in *Proceedings of the 7th Annual Conference on Evolutionary Programming*, pp. 601–610, 1998.
- [17] Y. Shi and R. Eberhart, "Parameter selection in particle swarm optimization," in *Proceedings of the 7th Annual Conference on Evolutionary Programming*, pp. 591–600, 1998.
- [18] M. A. Abido, "Optimal power flow using particle swarm optimization," *International Journal of Electrical Power and Energy Systems*, vol. 24, no. 7, pp. 563–571, 2002.

- [19] K. Thanushkodi, S. M. Vijayapandian, R. S. Dhivyapragash, M. Jothikumar, S. Sriramnivas, and K. Vinodh, "An efficient particle swarm optimization for economic dispatch problems with non-smooth cost function," *WSEAS Transactions on Power Systems*, vol. 3, no. 4, pp. 257–266, 2008.
- [20] K. S. Swarup, "Swarm intelligence approach to the solution of optimal power flow problem," *Journal of the Indian Institute of Science*, vol. 86, pp. 439–455, 2006.
- [21] P.-H. Chen, C.-C. Kuo, F.-H. Chen, and C.-C. Chen, "Refined binary particle swarm optimization and application in power system," *WSEAS Transactions on Systems*, vol. 8, no. 2, pp. 169–178, 2009.
- [22] R. Labdani, L. Slimani, and T. Bouktir, "Particle swarm optimization applied to economic dispatch problem," *Journal of Electrical Systems*, vol. 2, no. 2, pp. 95–102, 2006.
- [23] G. Baskar and M. R. Mohan, "Security constrained economic load dispatch using improved particle swarm optimization suitable for utility system," *International Journal of Electrical Power and Energy Systems*, vol. 30, no. 10, pp. 609–613, 2008.
- [24] M. A. Abido, "Multiobjective particle swarm optimization technique for environmental/economic dispatch problem," *Electric Power System Research*, vol. 79, no. 7, pp. 1105–1113, 2009.
- [25] L. Wang and C. Singh, "Stochastic economic emission load dispatch through a modified particle swarm optimization algorithm," *Electric Power Systems Research*, vol. 78, no. 8, pp. 1466–1476, 2008.
- [26] Y. del Valle, G. K. Venayagamoorthy, S. Mohagheghi, J.-C. Hernandez, and R. G. Harley, "Particle swarm optimization: basic concepts, variants and applications in power systems," *IEEE Transactions on Evolutionary Computation*, vol. 12, no. 2, pp. 171–195, 2008.
- [27] R. C. Eberhart and Y. Shi, "Comparison between genetic algorithms and particle swarm optimization, evolutionary programming VII," in *Proceedings of the 7th International Conference on Evolutionary Programming*, vol. 1447, pp. 611–616, Springer, 1998.
- [28] M. S. Arumugam and M. V. C. Rao, "On the performance of the particle swarm optimization algorithm with various inertia weight variants for computing optimal control of a class of hybrid systems," *Discrete Dynamics in Nature and Society*, Article ID 79295, 17 pages, 2006.